



**MUNSCH**  
**Plastic Pumps for Aggressive Media**

# Chemical pumps

## Vertical cantilever pump Type TPC-M

In PP/PE-UHMW/PVDF

- ▶ vertical setting depths up to 800 mm
- ▶ pump capacity up to 250 m<sup>3</sup>/h
- ▶ total differential head up to 60 m
- ▶ tolerant of solids
- ▶ dry run-proof

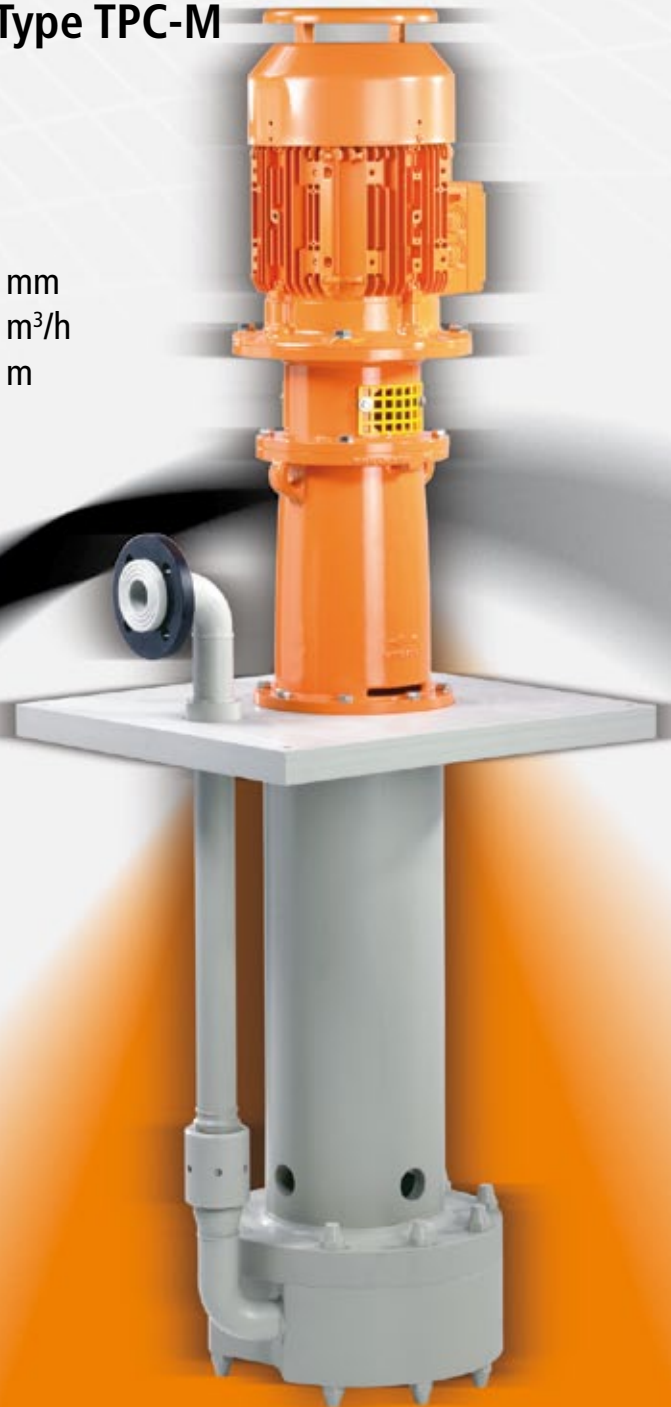

# Vertical cantilever pump TPC-M

## ► Applications

Dry run-proof Type TPC vertical cantilever pumps are the solution of choice whenever it comes to pumping solids-laden acids, alkalis or chemically contaminated effluents or when there is a risk of prolonged dry running. Typical applications include the metal finishing industry, steel and stainless steel pickling lines, evaporation and regeneration units, flue gas cleaning systems downstream of waste incinerators as well as exhaust air cleaning and scrubber effluent treatment.

## ► Construction

Vertical centrifugal pump with volute casing and single-entry, single-stage radial impeller; without bottom bearing; the shaft bearing is located outside the path of the fluid pumped.

## ► Materials

Part designation	Standard material range		
	PP	PE-UHMW	PVDF
Pump casing	PP	PE-UHMW	PVDF
Casing cover	PP	PE-UHMW	PVDF
Pump shaft	St		
Impeller	PP <sup>1)</sup>	PE-UHMW <sup>1)</sup>	PVDF <sup>1)</sup>
Bearing lantern	GGG		
Secondary seals <sup>2)</sup>	FPM		
Shaft protection sleeve	PP	PP	PVDF
Column pipe	PP	PP	PVDF
Suspension pipe	PP	PP	PVDF
Casing flange	PP	PP	PVDF
Sole plate	PP	PP	PP

1) Material combinations possible

2) Alternatives (depending on fluid pumped): EPDM or Viton-PTFE-coated

PP	Polypropylen
PE-UHMW	Ultrahigh-molecular polyethylene
PVDF	Polyvinylidene fluoride
FPM	Fluoroelastomer
EPDM	Ethylene propylene diene elastomer
PTFE	Polytetrafluoroethylene

## ► Performance data for 50/60 Hz operation<sup>3)</sup>

Pump capacity [Q] up to	250 m <sup>3</sup> /h
Total differential head [H] up to	60 m
Motor rating [P] up to	20 kW
Vertical setting depths [I] up to	800 mm

3) Performance data for standard pumps; extended performance ranges on request

## ► Shaft seal

Labyrinth seal, optional V-ring seal

## ► Flange connection

Standard design with stub end and backing flange to DIN, optionally to ANSI or JIS.

## ► Drive

Three-phase A.C. motor, design V1 with canopy to IEC, BS or NEMA; type of protection, flameproof enclosure and motor voltage to customer specifications.

## ► Coating

Paint system for metallic pump components:  
Base coat: epoxy resin primer; Top coat: PU-based finish, RAL 2003, pastel orange. Total dry film thickness 130–150 µm. Special coatings available on request.

## ► Maximum allowable service pressures and temperatures

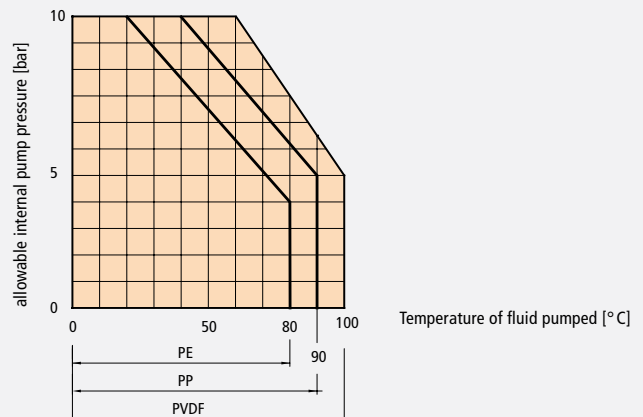

## ► Arrangement

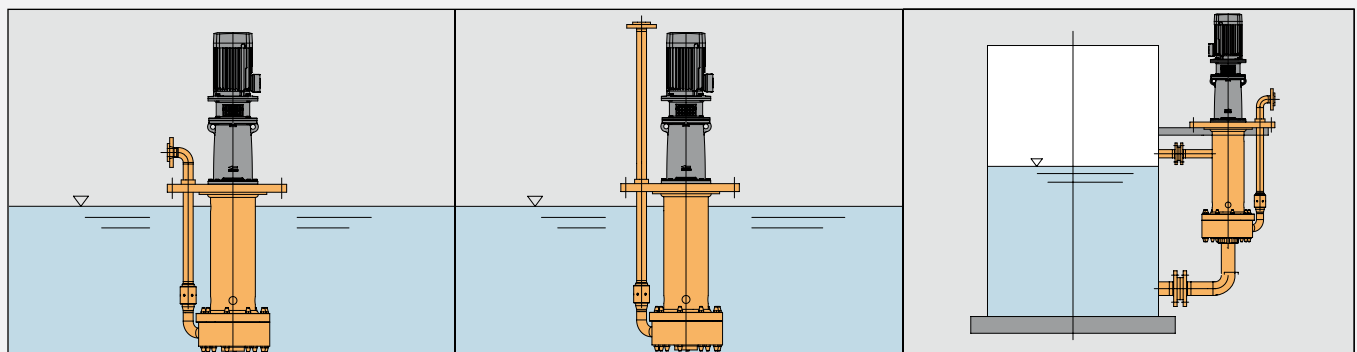

3.1) With flange and elbow, wet-end installation

3.2) With top flange, wet-end installation

3.3) With flange and elbow, dry-end installation

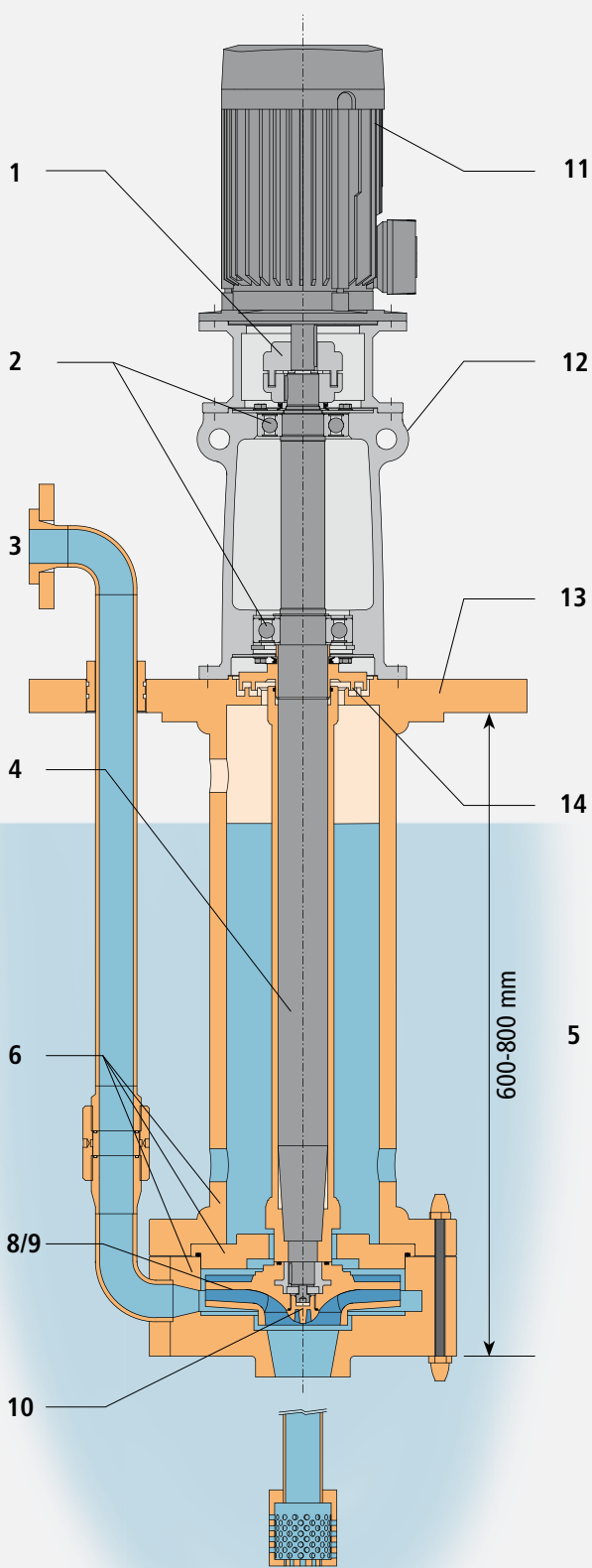

## ► Design features

- 1 Flexible coupling connecting motor shaft to pump shaft.
- 2 Anti-friction bearing installed in lantern. Shaft bearing can accommodate high loads even under part load conditions.
- 3 Column pipe with 90° elbow and flange; connection by a suitable pipe union allows the column pipe and/or the discharge flange to be rotated to virtually any position (Fig. 3.1).  
Option: column pipe with flange or design to customer's specification (Fig. 3.2)
- 4 Steel shaft with solid plastic protection sleeve
- 5 Standard setting depths 600 mm and 800 mm
- 6 Volute casing, casing cover and suspension pipe made of solid plastics; with ample abrasion allowance; maximum reliability when handling corrosives and abrasives.
- 7 Solid impeller hub ensures plastics stability even at high temperatures.
- 8 Impeller: closed design (Fig. 8.1); semi-open (Fig. 8.2) or vortex (Fig. 8.3) impellers can be provided on request.
- 9 Optimum hydraulic design using the latest numerical methods ensures:
  - good suction behaviour due to low NPSH requirements
  - minimum mechanical vibration of components
  - long service life of anti-friction bearings
  - minimized running noise.

Pump size	Maximum allowable particle size [mm]	
	Impeller design	
	semi-open and closed	Vortex impeller
50-32-125	8	10
50-32-160	6	10
50-32-200	5	10
65-40-160	8	12
65-40-200	8	12
65-50-125	10	16
80-50-200	8	16
80-65-160	10	16
80-50-250	10	16
80-50-315	10	16
100-65-200	12	16
100-65-250	12	16
125-80-200	12	18
125-100-200	15	24

Accessories/Option: Suction strainer/suction pipe

- 10 Impeller is positively locked to the shaft for reverse rotation protection..
- 11 Standard motor, design V1 with canopy
- 12 Low external height above, slim construction below the sole plate
- 13 Circular or rectangular sole plate; special sole plate geometries and sole plates with supporting flange available on request.
- 14 Non-contacting Type 10 labyrinth seal integrated into the sole plate prevents product escaping to the atmosphere. It is typically used in service environments involving no environmental hazards and when the pump tank is vented.

► **Accessories/Options**

- Suction strainer
- Suction pipe up to a length of 1600 mm
- Suction strainer and suction pipe
- Motor overload switch (not shown)

► **Explosion protection to EU Directive 94/9/EG (option)**

Additional constructional measures allow the use of the TPC in explosion hazard areas. The pump meets the requirements of EU Directive No. 94/9/EG.

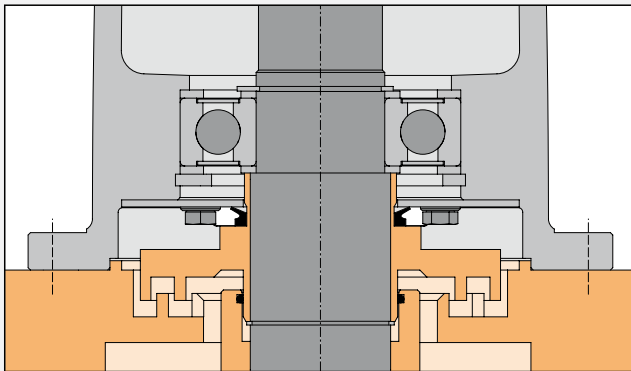

14) Type 10 labyrinth seal

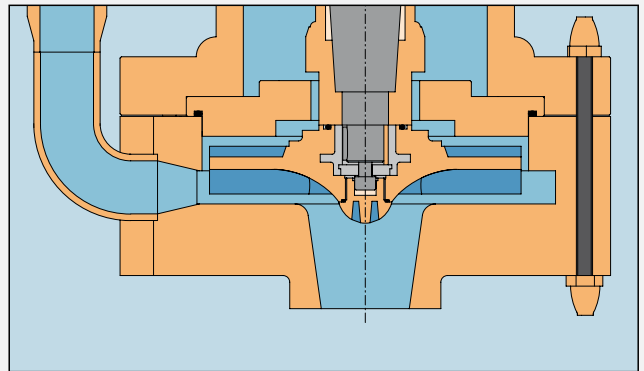

8.2) Semi-open impeller

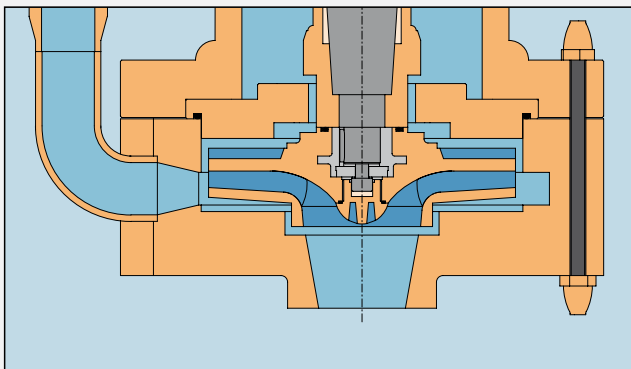

8.1) Closed impeller

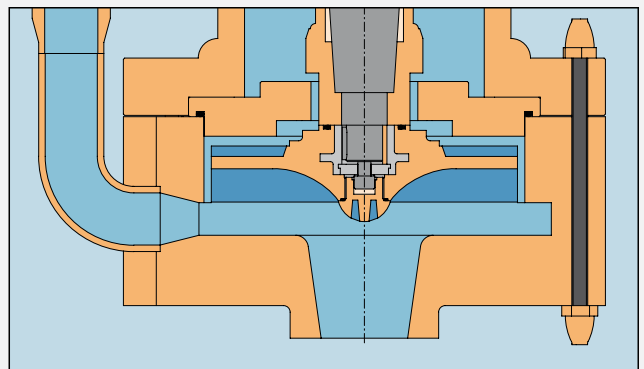

8.3) Vortex impeller

► Performance characteristic charts

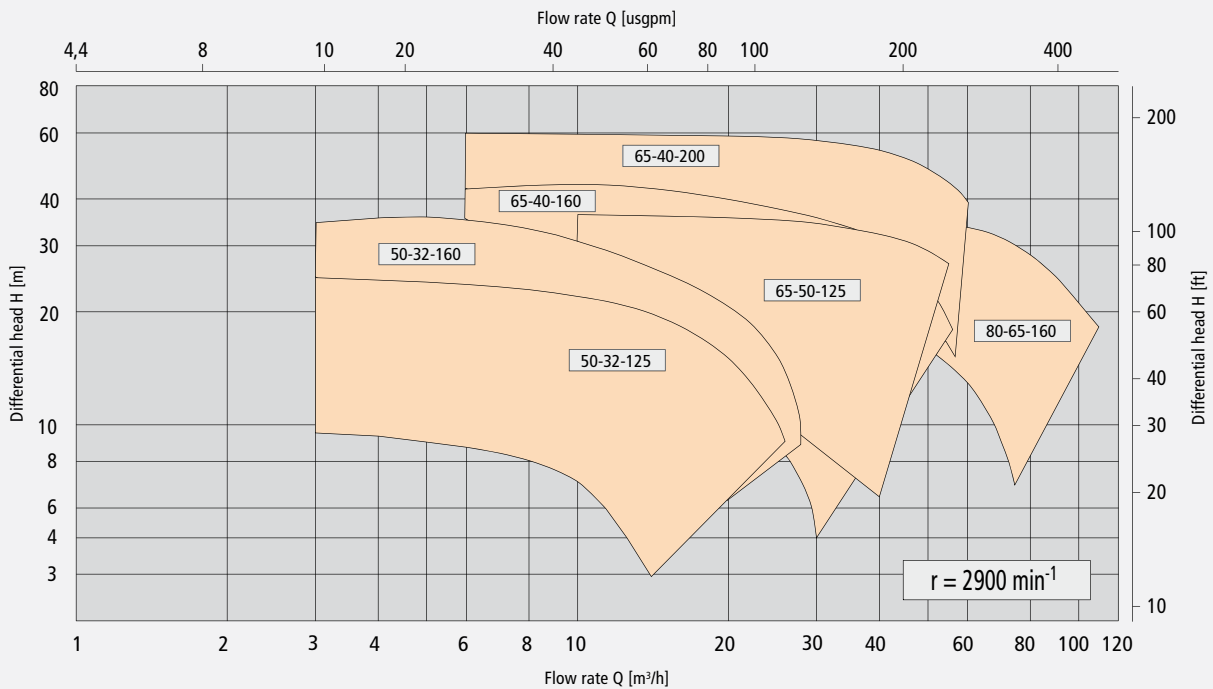
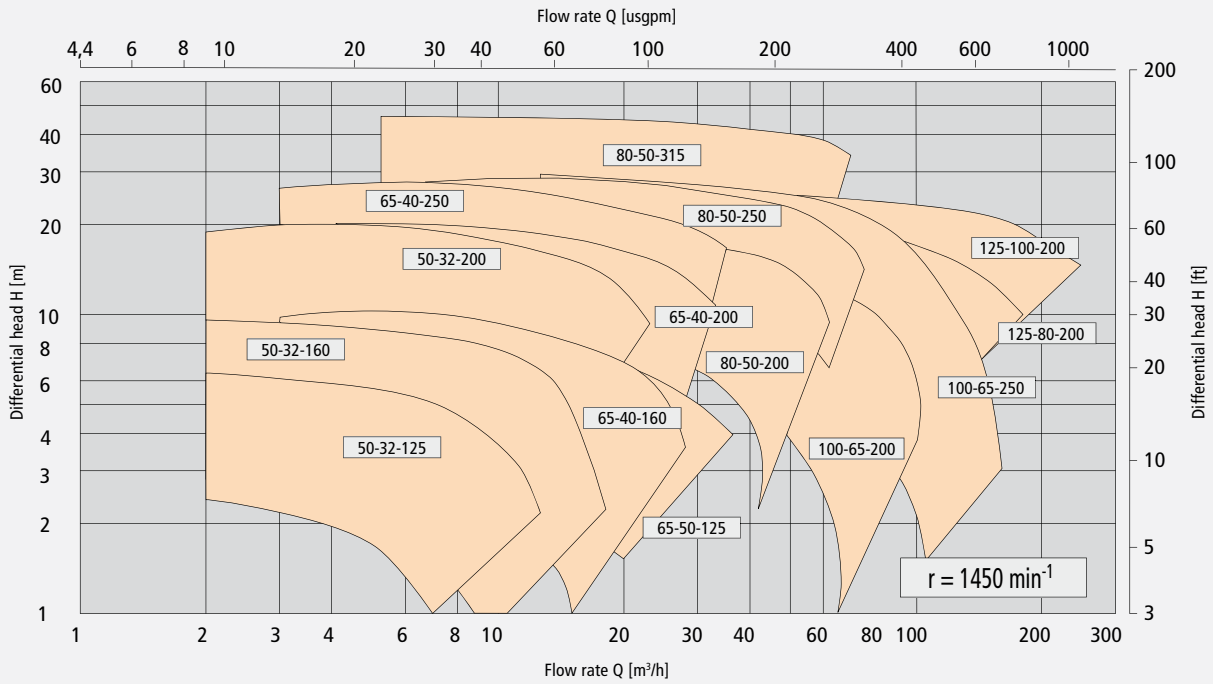

# Vertical cantilever pump TPC-M

## ► Dimensions – Standard design

Pumpengröße	DNd	DNs	a	ØC	D	E	E2	K	LK	p	t
50-32-125	50	32	4	480	295	180	0	365	440	12,5	40
50-32-160	50	32	4	480	295	180	0	365	440	12,5	40
50-32-200	50	32	6	540	370	225	20	445	508	12,5	40
65-40-160	65	40	4	480	295	180	0	370	440	12,5	40
65-40-200	65	40	6	540	370	225	20	450	508	12,5	40
65-50-125	65	50	4	540	295	210	0	405	508	12,5	40
80-50-200	80	50	6	540	370	225	20	455	508	12,5	40
80-65-160	80	65	8	590	390	255	60	480	558	12,5	55
80-50-250	80	50	8	590	425	245	45	490	558	12,5	55
80-50-315	80	50	10	700	520	285	20	595	668	12,5	55
100-65-200	100	65	8	590	425	245	45	500	558	12,5	55
100-65-250	100	65	8	640	450	250	20	525	608	12,5	55
125-80-200	125	80	8	590	425	245	45	515	558	12,5	55
125-100-200	125	100	10	700	460	305	60	600	668	12,5	55

A = 600 or 800 (Standard)

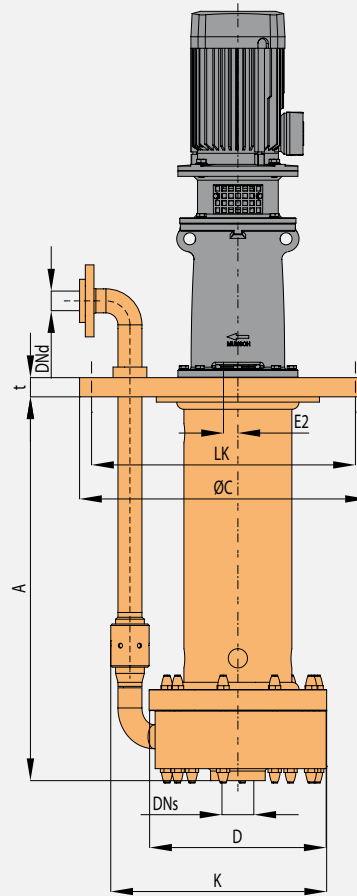

## ► Sole plate

The standard pump comes with a circular (1) or rectangular (2) sole plate; sole plates with supporting flange (3) and special designs can be provided on request.

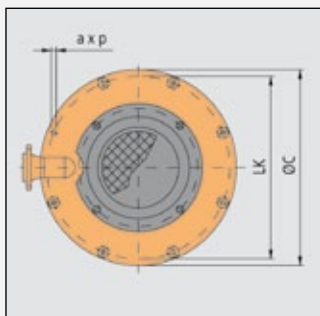

1) Circular sole plate

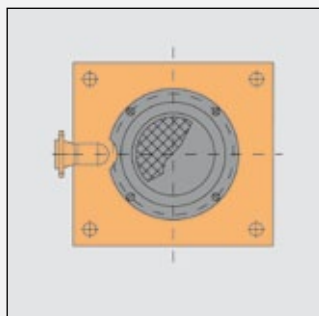

2) Rectangular sole plate

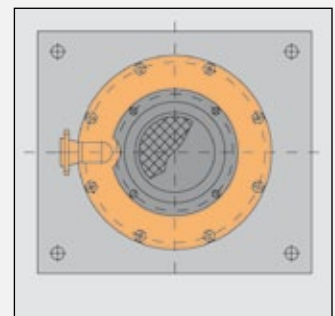

3) Circular sole plate with supporting flange

### MUNSCH Chemie-Pumpen GmbH

Im Staudchen · D-56235 Ransbach-Baumbach  
P.O. Box 1 42 · D-56221 Ransbach-Baumbach  
Germany

Phone: +49 (0) 2623-8 98-90

Fax: +49 (0) 2623-8 98-95

Internet: <http://www.munsch.de>

E-Mail: [munsch@munsch.de](mailto:munsch@munsch.de)